

- NOTES:
 1. BEAM AND JOIST SCHEDULE
 B1 - 5/2"x11/4" GLB
 J1 - 117/8" TJI 560 @ 16" o.c.
 J2 - 117/8" TJI 560 @ 12" o.c.
 2. INDICATES 1/2" PLYWOOD W/ 10@6" o.c.,
 E.N. AND 10@12" o.c. F.N.

MEZZANINE FRAMING LAYOUT
 SKS040707-09 SCALE: 1/8" = 1'-0"

B.V. MD

NISHKIAN MENNINGER

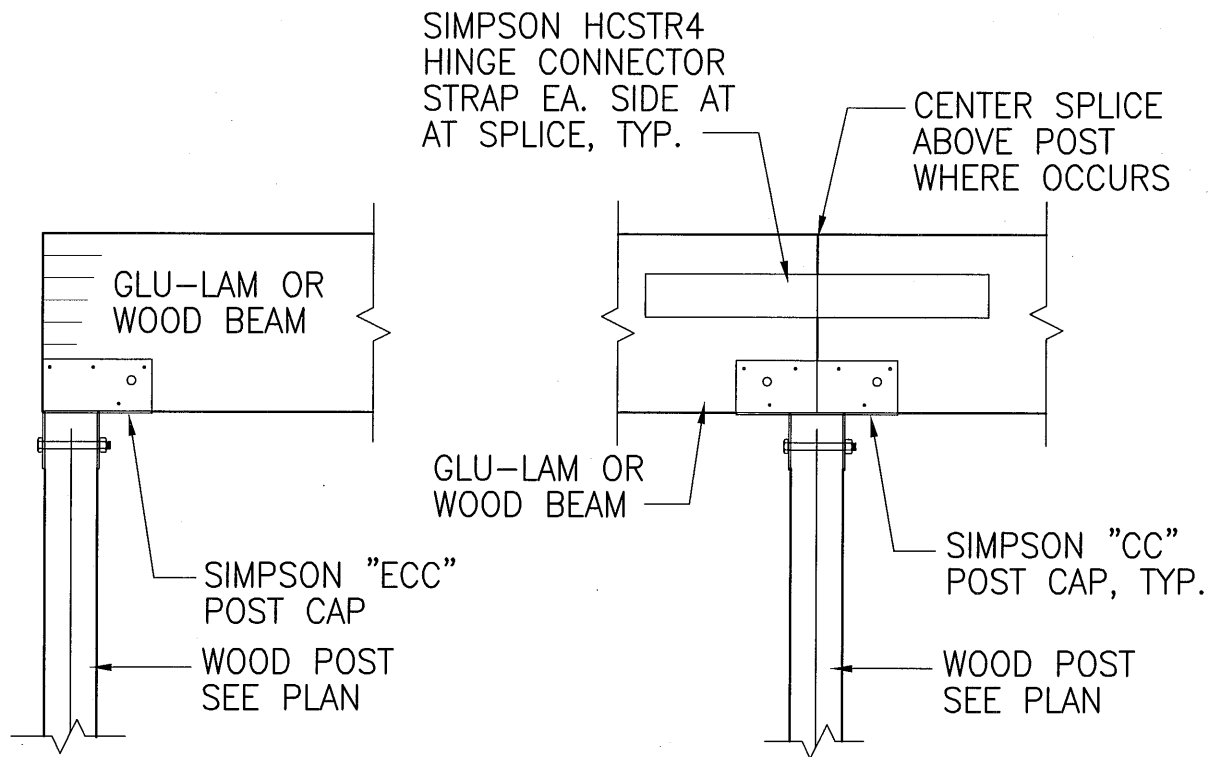

END OF BEAM

AT BEAM SPLICE
OR CONTINUOUS BEAM

⊖ WOOD BEAM TO WOOD POST DETAIL
SKS040707-10

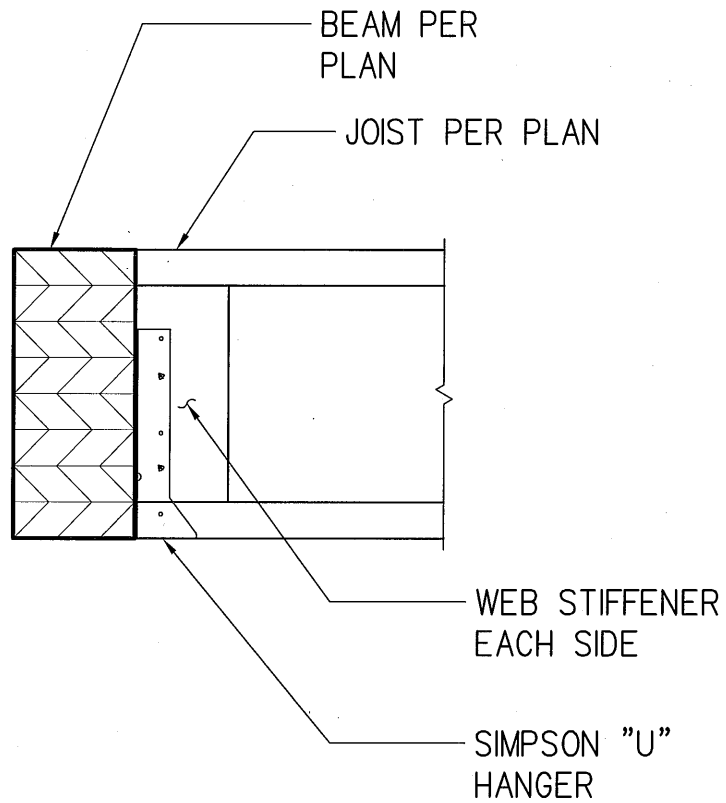

I-JOIST TO GLULAM DETAIL

SKS040707-11

SCALE: 1 1/2" = 1'-0"

MISHELAN MENNINGER

By: MD

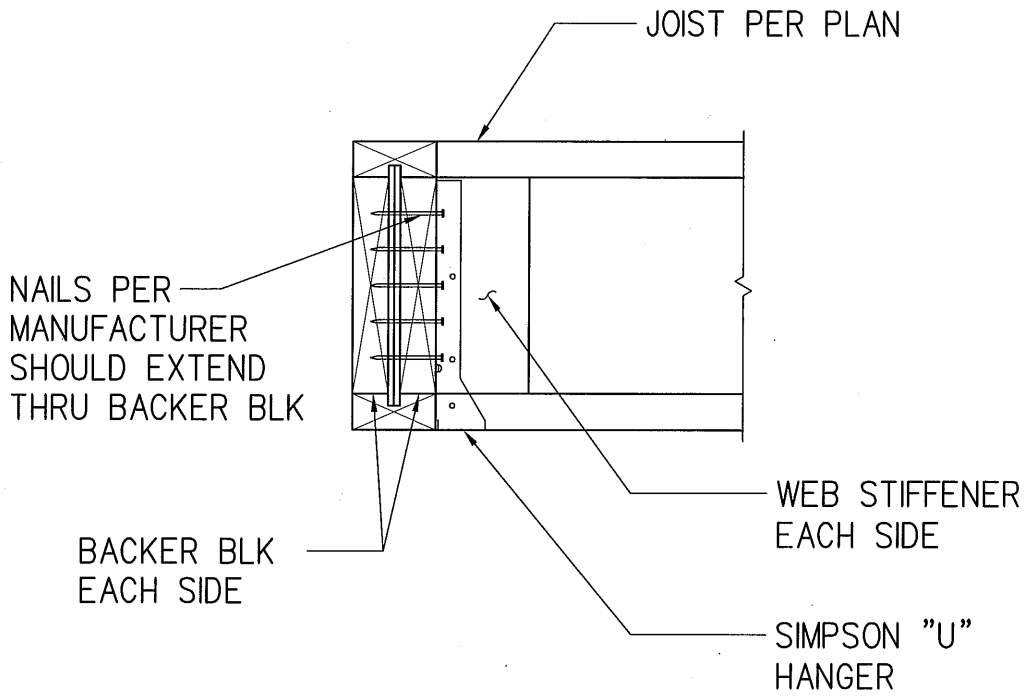

BLKG AT I-JOIST DETAIL

SKS040707-12

SCALE: 1 1/2" = 1'-0"

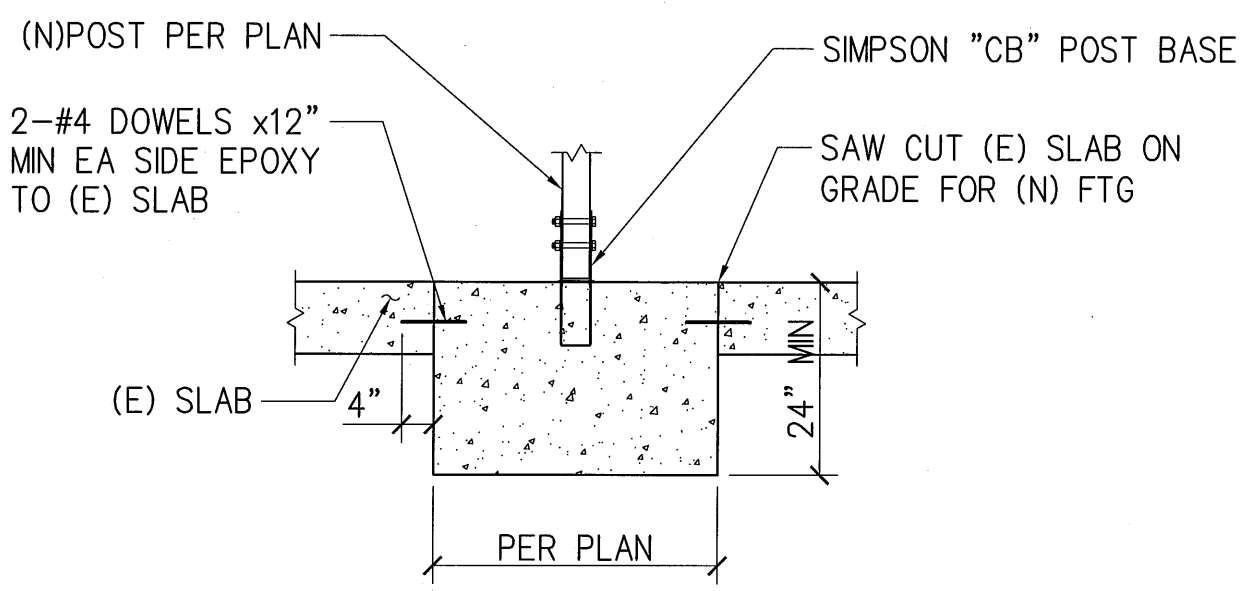

(N) POST TO (N) FOOTING DETAIL

SKS040707-13

SCALE: 3/4" = 1'-0"

NISHKIAN MENNINGER

BY: MD